

HW 17 SOLUTIONS

4-1. The ship is pushed through the water using an A-36 steel propeller shaft that is 8 m long, measured from the propeller to the thrust bearing *D* at the engine. If it has an outer diameter of 400 mm and a wall thickness of 50 mm, determine the amount of axial contraction of the shaft when the propeller exerts a force on the shaft of 5 kN. The bearings at *B* and *C* are journal bearings.

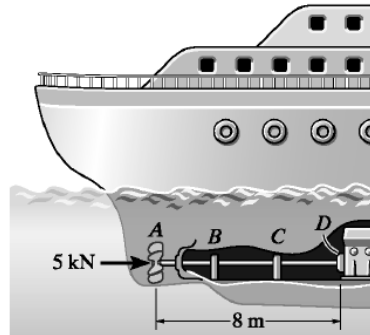

Internal Force : As shown on FBD.
Displacement :

$$\delta_A = \frac{PL}{AE} = \frac{-5.00(10^3)(8)}{\frac{\pi}{4}(0.4^2 - 0.3^2)200(10^9)}$$

$$= -3.638(10^{-6}) \text{ m}$$

$$= -3.64(10^{-3}) \text{ mm} \quad \text{Ans}$$

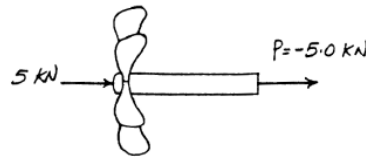

Negative sign indicates that end *A* moves towards end *D*.

***4-4.** The copper shaft is subjected to the axial loads shown. Determine the displacement of end *A* with respect to end *D* if the diameters of each segment are $d_{AB} = 0.75 \text{ in.}$, $d_{BC} = 1 \text{ in.}$, and $d_{CD} = 0.5 \text{ in.}$ Take $E_{cu} = 18(10^3) \text{ ksi.}$

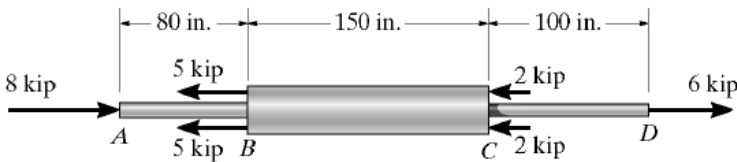

$$\delta_{AD} = \sum \frac{PL}{AE} = \frac{-8(80)}{\frac{\pi}{4}(0.75)^2(18)(10^3)} + \frac{2(150)}{\frac{\pi}{4}(1)^2(18)(10^3)} + \frac{6(100)}{\frac{\pi}{4}(0.5)^2(18)(10^3)}$$

$$= 0.111 \text{ in.} \quad \text{Ans}$$

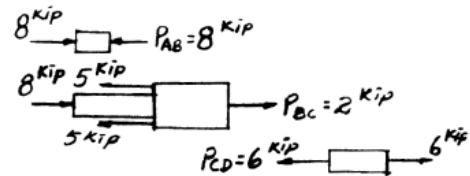

The positive sign indicates that end *A* moves away from end *D*.

4-6. The assembly consists of an A-36 steel rod CB and a 6061-T6 aluminum rod BA , each having a diameter of 1 in. Determine the applied loads P_1 and P_2 if A is displaced 0.08 in. to the right and B is displaced 0.02 in. to the left when the loads are applied. The unstretched length of each segment is shown in the figure. Neglect the size of the connections at B and C , and assume that they are rigid.

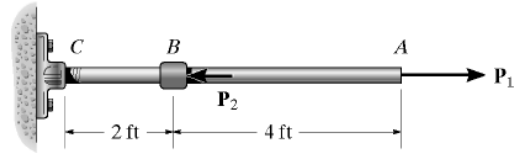

Internal Forces : As shown on FBD.

Displacement :

For point A

$$\delta_A = \sum \frac{PL}{AE}; \quad 0.08 = \frac{P_1(4)(12)}{\frac{\pi}{4}(1^2)(10.0)(10^3)} + \frac{(P_1 - P_2)(2)(12)}{\frac{\pi}{4}(1^2)(29.0)(10^3)}$$

$$2.618 = 0.2344 P_1 - 0.03448 P_2 \quad [1]$$

For point B

$$\delta_B = \sum \frac{PL}{AE}; \quad -0.02 = \frac{(P_1 - P_2)(2)(12)}{\frac{\pi}{4}(1^2)(29.0)(10^3)}$$

$$18.980 = P_2 - P_1 \quad [2]$$

Solving Eqs. [1] and [2] yields :

$$P_1 = 16.4 \text{ kip} \quad \text{Ans}$$

$$P_2 = 35.3 \text{ kip} \quad \text{Ans}$$

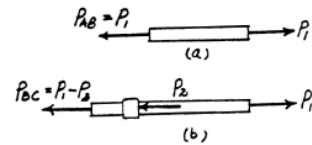

*4-8. The load is supported by the four 304 stainless steel wires that are connected to the rigid members AB and DC . Determine the vertical displacement of the 500-lb load if the members were horizontal when the load was originally applied. Each wire has a cross-sectional area of 0.025 in^2 .

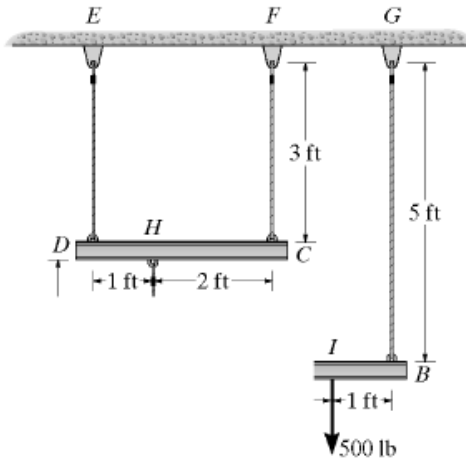

Internal Forces in the wires :

FBD (b)

$$+\Sigma M_A = 0; \quad F_{BG}(4) - 500(3) = 0 \quad F_{BG} = 375.0 \text{ lb}$$

$$+\uparrow \Sigma F_y = 0; \quad F_{AH} + 375.0 - 500 = 0 \quad F_{AH} = 125.0 \text{ lb}$$

FBD (a)

$$+\Sigma M_D = 0; \quad F_{CF}(3) - 125.0(1) = 0 \quad F_{CF} = 41.67 \text{ lb}$$

$$+\uparrow \Sigma F_y = 0; \quad F_{DE} + 41.67 - 125.0 = 0 \quad F_{DE} = 83.33 \text{ lb}$$

Displacement :

$$\delta_D = \frac{F_{DE}L_{DE}}{A_{DE}E} = \frac{83.33(3)(12)}{0.025(28.0)(10^6)} = 0.0042857 \text{ in.}$$

$$\delta_C = \frac{F_{CF}L_{CF}}{A_{CF}E} = \frac{41.67(3)(12)}{0.025(28.0)(10^6)} = 0.0021429 \text{ in.}$$

$$\frac{\delta'_H}{2} = \frac{0.0021429}{3}; \quad \delta'_H = 0.0014286 \text{ in.}$$

$$\delta_H = 0.0014286 + 0.0021429 = 0.0035714 \text{ in.}$$

$$\delta_{A/H} = \frac{F_{AH}L_{AH}}{A_{AH}E} = \frac{125.0(1.8)(12)}{0.025(28.0)(10^6)} = 0.0038571 \text{ in.}$$

$$\delta_A = \delta_H + \delta_{A/H} = 0.0035714 + 0.0038571 = 0.0074286 \text{ in.}$$

$$\delta_B = \frac{F_{BG}L_{BG}}{A_{BG}E} = \frac{375.0(5)(12)}{0.025(28.0)(10^6)} = 0.0321428 \text{ in.}$$

$$\frac{\delta'_I}{3} = \frac{0.0247143}{4}; \quad \delta'_I = 0.0185357 \text{ in.}$$

$$\delta_I = 0.0074286 + 0.0185357 = 0.0260 \text{ in.} \quad \text{Ans}$$

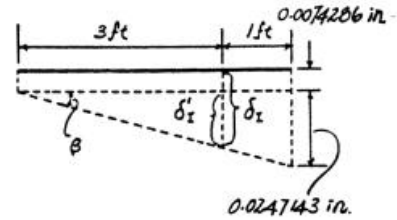
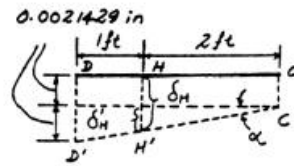
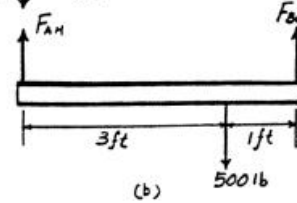
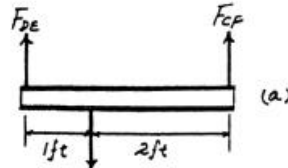

*4-12. The assembly consists of three titanium (Ti-6Al-4V) rods and a rigid bar AC. The cross-sectional area of each rod is given in the figure. If a force of 6 kip is applied to the ring F, determine the angle of tilt of bar AC.

Internal Force in the Rods :

$$\curvearrowleft + \Sigma M_A = 0; \quad F_{CD}(3) - 6(1) = 0 \quad F_{CD} = 2.00 \text{ kip}$$

$$\rightarrow \Sigma F_x = 0; \quad 6 - 2.00 - F_{AB} = 0 \quad F_{AB} = 4.00 \text{ kip}$$

Displacement :

$$\delta_C = \frac{F_{CD}L_{CD}}{A_{CD}E} = \frac{2.00(4)(12)}{(1)(17.4)(10^3)} = 0.0055172 \text{ in.}$$

$$\delta_A = \frac{F_{AB}L_{AB}}{A_{AB}E} = \frac{4.00(6)(12)}{(1.5)(17.4)(10^3)} = 0.0110344 \text{ in.}$$

$$\theta = \tan^{-1} \frac{\delta_A - \delta_C}{3(12)} = \tan^{-1} \frac{0.0110344 - 0.0055172}{3(12)}$$

$$= 0.00878^\circ \quad \text{Ans}$$

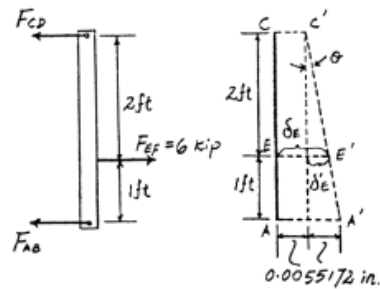
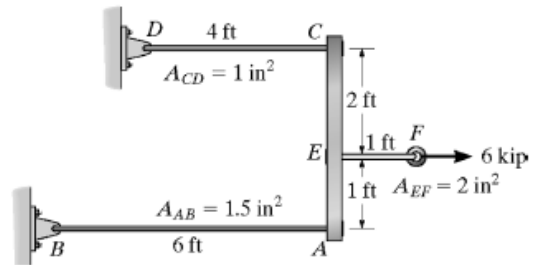

4-15. The assembly consists of three titanium rods and a rigid bar AC. The cross-sectional area of each rod is given in the figure. If a vertical force $P = 20$ kN is applied to the ring F , determine the vertical displacement of point F . $E_{Ti} = 350$ GPa.

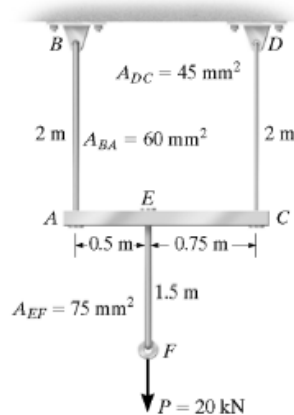

$$\delta_A = \frac{PL}{AE} = \frac{12(10^3)(2000)}{(60)(10^{-6})(350)(10^9)} = 1.1429 \text{ mm}$$

$$\delta_C = \frac{PL}{AE} = \frac{8(10^3)(2000)}{45(10^{-6})(350)(10^9)} = 1.0159 \text{ mm}$$

$$\delta_{F/E} = \frac{PL}{AE} = \frac{20(10^3)(1500)}{75(10^{-6})(350)(10^9)} = 1.1429 \text{ mm}$$

$$\delta_E = 1.0159 + \frac{0.75}{1.25}(0.1270) = 1.092 \text{ mm}$$

$$\delta_F = \delta_E + \delta_{F/E}$$

$$= 1.092 + 1.1429$$

$$= 2.23 \text{ mm} \quad \text{Ans}$$

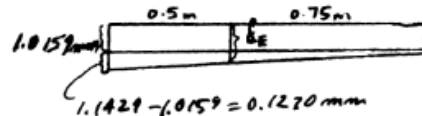
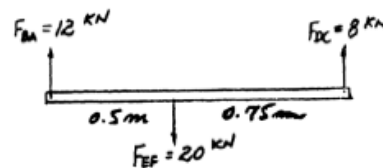

4-70. The electrical switch closes when the linkage rods CD and AB heat up, causing the rigid arm BDE both to translate and rotate until contact is made at F . Originally, BDE is vertical, and the temperature is 20°C . If AB is made of bronze C86100 and CD is made of aluminum 6061-T6, determine the gap s required so that the switch will close when the temperature becomes 110°C .

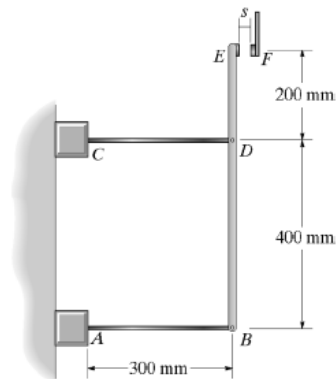

Thermal Expansion :

$$\delta_{AB} = \alpha_{cu} \Delta TL = 17.0(10^{-6})(110 - 20)(300) = 0.4590 \text{ mm}$$

$$\delta_{CD} = \alpha_{al} \Delta TL = 24.0(10^{-6})(110 - 20)(300) = 0.6480 \text{ mm}$$

Geometry :

$$\begin{aligned} s &= \delta_{AB} + (\delta_{CD} - \delta_{AB}) \left(\frac{600}{400} \right) \\ &= 0.4590 + (0.6480 - 0.4590) \left(\frac{600}{400} \right) \\ &= 0.7425 \text{ mm} \end{aligned}$$

Ans

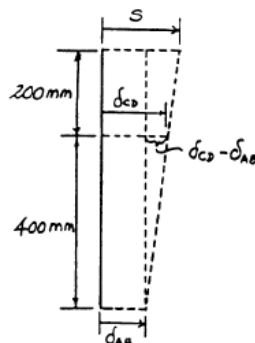

4-71. A steel surveyor's tape is to be used to measure the length of a line. The tape has a rectangular cross section of 0.05 in. by 0.2 in. and a length of 100 ft when $T_1 = 60^\circ\text{F}$ and the tension or pull on the tape is 20 lb. Determine the true length of the line if the tape shows the reading to be 463.25 ft when used with a pull of 35 lb at $T_2 = 90^\circ\text{F}$. The ground on which it is placed is flat. $\alpha_{st} = 9.60(10^{-6})/^\circ\text{F}$, $E_{st} = 29(10^3)$ ksi.

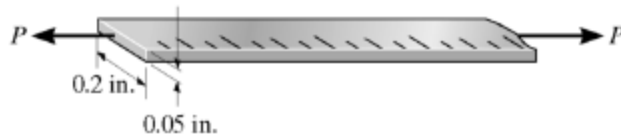

$$\delta_T = \alpha \Delta T L = 9.6(10^{-6})(90 - 60)(463.25) = 0.133416 \text{ ft}$$

$$\delta = \frac{PL}{AE} = \frac{(35 - 20)(463.25)}{(0.2)(0.05)(29)(10^6)} = 0.023961 \text{ ft}$$

$$L = 463.25 + 0.133416 + 0.023961 = 463.41 \text{ ft} \quad \text{Ans}$$

***4-76.** The 40-ft-long A-36 steel rails on a train track are laid with a small gap between them to allow for thermal expansion. Determine the required gap δ so that the rails just touch one another when the temperature is increased from $T_1 = -20^\circ\text{F}$ to $T_2 = 90^\circ\text{F}$. Using this gap, what would be the axial force in the rails if the temperature were to rise to $T_3 = 110^\circ\text{F}$? The cross-sectional area of each rail is 5.10 in^2 .

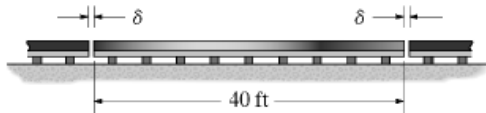

Thermal Expansion : Note that since adjacent rails expand, each rail will be required to expand $\frac{\delta}{2}$ on each end, or δ for the entire rail.

$$\delta = \alpha \Delta T L = 6.60(10^{-6})[90 - (-20)](40)(12) = 0.34848 \text{ in.} = 0.348 \text{ in.} \quad \text{Ans}$$

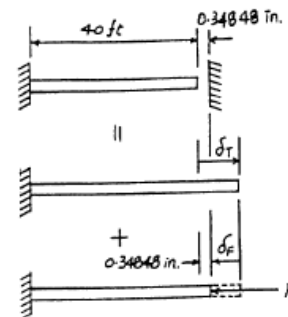

Compatibility :

$$(\rightarrow) \quad 0.34848 = \delta_T - \delta_F$$

$$0.34848 = 6.60(10^{-6})[110 - (-20)](40)(12) - \frac{F(40)(12)}{5.10(29.0)(10^3)}$$

$$F = 19.5 \text{ kip}$$

Ans

4-78. The two circular rod segments, one of aluminum and the other of copper, are fixed to the rigid walls such that there is a gap of 0.008 in. between them when $T_1 = 60^\circ\text{F}$. Each rod has a diameter of 1.25 in., $\alpha_{\text{al}} = 13(10^{-6})/^\circ\text{F}$, $E_{\text{al}} = 10(10^3)$ ksi, $\alpha_{\text{cu}} = 9.4(10^{-6})/^\circ\text{F}$, $E_{\text{cu}} = 18(10^3)$ ksi. Determine the average normal stress in each rod if $T_2 = 300^\circ\text{F}$, and also calculate the new length of the aluminum segment.

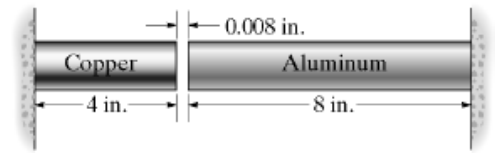

Compatibility :

$$0.008 = (\delta_T)_{\text{cu}} - (\delta_F)_{\text{cu}} + (\delta_T)_{\text{al}} - (\delta_F)_{\text{al}}$$

$$0.008 = 9.4(10^{-6})(300-60)(4) - \frac{F(4)}{\frac{\pi}{4}(1.25^2)(18)(10^3)}$$

$$+ 13(10^{-6})(300-60)(8) - \frac{F(8)}{\frac{\pi}{4}(1.25^2)(10)(10^3)}$$

$$F = 31.194 \text{ kip}$$

Average Normal Stress :

$$\sigma_{\text{al}} = \sigma_{\text{cu}} = \frac{F}{A} = \frac{31.194}{\frac{\pi}{4}(1.25^2)} = 25.4 \text{ ksi} \quad \text{Ans}$$

Displacement :

$$\delta_{\text{al}} = (\delta_T)_{\text{al}} - (\delta_F)_{\text{al}}$$

$$= 13(10^{-6})[300-60](8) - \frac{31.194(8)}{\frac{\pi}{4}(1.25^2)(10)(10^3)}$$

$$= 0.0046247 \text{ in.}$$

$$L'_{\text{al}} = L_{\text{al}} + \delta_{\text{al}} = 8 + 0.0046247 = 8.00462 \text{ in.} \quad \text{Ans}$$

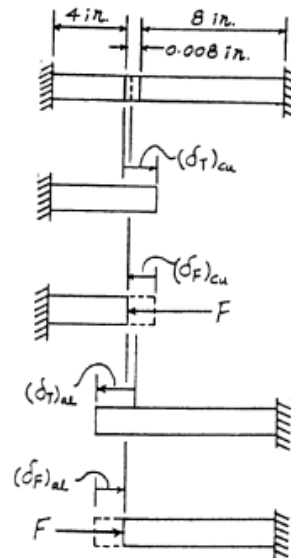

*4-88. If the allowable normal stress for the bar is $\sigma_{\text{allow}} = 120 \text{ MPa}$, determine the maximum axial force P that can be applied to the bar.

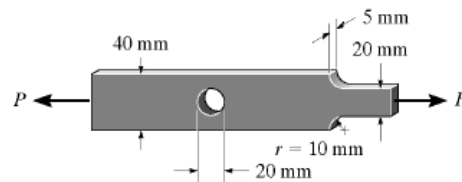

Assume failure of the fillet.

$$\frac{w}{h} = \frac{40}{20} = 2; \quad \frac{r}{h} = \frac{10}{20} = 0.5$$

From Fig. 4-23, $K = 1.4$

$$\sigma_{\text{allow}} = \sigma_{\text{max}} = K\sigma_{\text{avg}}$$

$$120(10^6) = 1.4 \left(\frac{P}{0.02(0.005)} \right)$$

$$P = 8.57 \text{ kN}$$

Assume failure of the hole.

$$\frac{r}{w} = \frac{10}{40} = 0.25$$

From Fig. 4-24, $K = 2.375$

$$\sigma_{\text{allow}} = \sigma_{\text{max}} = K\sigma_{\text{avg}}$$

$$120(10^6) = 2.375 \left(\frac{P}{(0.04 - 0.02)(0.005)} \right)$$

$$P = 5.05 \text{ kN} \quad (\text{controls}) \quad \mathbf{Ans}$$

4-89. The steel bar has the dimensions shown. Determine the maximum axial force P that can be applied so as not to exceed an allowable tensile stress of $\sigma_{\text{allow}} = 150 \text{ MPa}$.

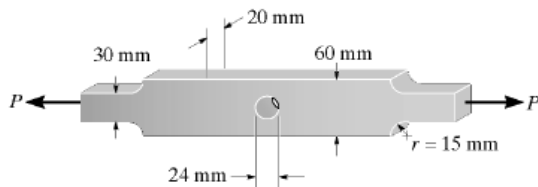

Assume failure occurs at the fillet :

$$\frac{w}{h} = \frac{60}{30} = 2 \quad \text{and} \quad \frac{r}{h} = \frac{15}{30} = 0.5$$

From the text, $K = 1.4$

$$\sigma_{\text{max}} = \sigma_{\text{allow}} = K\sigma_{\text{avg}}$$

$$150(10^6) = 1.4 \left[\frac{P}{0.03(0.02)} \right]$$

$$P = 64.3 \text{ kN}$$

Assume failure occurs at the hole :

$$\frac{r}{w} = \frac{15}{60} = 0.25$$

From the text, $K = 2.45$

$$\sigma_{\text{max}} = \sigma_{\text{allow}} = K\sigma_{\text{avg}}$$

$$150(10^6) = 2.45 \left[\frac{P}{(0.06 - 0.024)(0.02)} \right]$$

$$P = 44.1 \text{ kN} \quad (\text{controls!}) \quad \mathbf{Ans}$$

*4-92. Determine the maximum normal stress developed in the bar when it is subjected to a tension of $P = 8 \text{ kN}$.

Maximum Normal Stress at fillet :

$$\frac{r}{h} = \frac{15}{30} = 0.5 \quad \text{and} \quad \frac{w}{h} = \frac{60}{30} = 2$$

From the text, $K = 1.4$

$$\begin{aligned} \sigma_{\max} &= K \sigma_{\text{avg}} = K \frac{P}{h t} \\ &= 1.4 \left[\frac{8(10^3)}{(0.03)(0.005)} \right] = 74.7 \text{ MPa} \end{aligned}$$

Maximum Normal Stress at the hole :

$$\frac{r}{w} = \frac{6}{60} = 0.1$$

From the text, $K = 2.65$

$$\begin{aligned} \sigma_{\max} &= K \sigma_{\text{avg}} = K \frac{P}{(w - 2r) t} \\ &= 2.65 \left[\frac{8(10^3)}{(0.06 - 0.012)(0.005)} \right] \\ &= 88.3 \text{ MPa} \quad (\text{Controls}) \end{aligned}$$

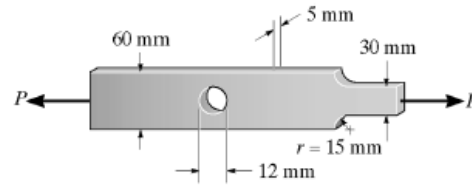

Ans